

Ref. **3170**

MACHO HELICOIDAL MÁQUINA MÉTRICA MATERIALES DUROS M. REFORZADO

Reinforced Shank Hard Materials Metric Machine Spiral Tap
Taraud Hélicoïdal Machine Métrique Matériaux Durs Queue Renforcée



PMX TIALN DIN 371 C 2-3h Tol. 6H 15° α 4° ± 1 60°

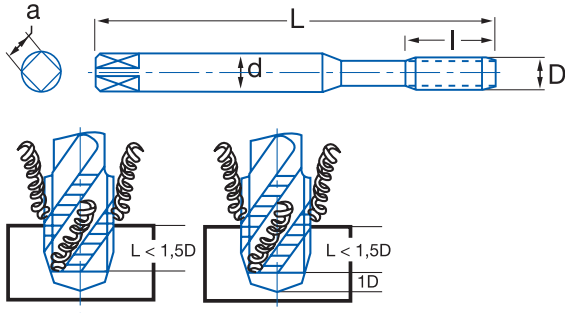

Material		Vc
Grupo	Sub.	TIALN
1	1.3	4-8
1	1.4	3-5
4		10-15
7	7.2	20-30

Vc= m/min.

M	P	L mm	l mm	d mm	a mm	Z	Nº Art. TIALN	€
M3	0,50	56	11	3,50	2,70	3	15366	26,65
M4	0,70	63	13	4,50	3,40	3	15367	26,65
M5	0,80	70	16	6,00	4,90	3	15369	26,65
M6	1,00	80	19	6,00	4,90	3	15372	28,04
M8	1,25	90	22	8,00	6,20	3	15373	33,56
M10	1,50	100	24	10,00	8,00	3	15375	41,70

Ref. **3270**

MACHO HELICOIDAL MÁQUINA MÉTRICA MATERIALES DUROS

Hard Materials Metric Machine Spiral Tap
Taraud Hélicoïdal Machine Métrique Matériaux Durs



PMX TIALSIN DIN 376 C 2-3h Tol. 6H 15° α 4° ± 1 60°

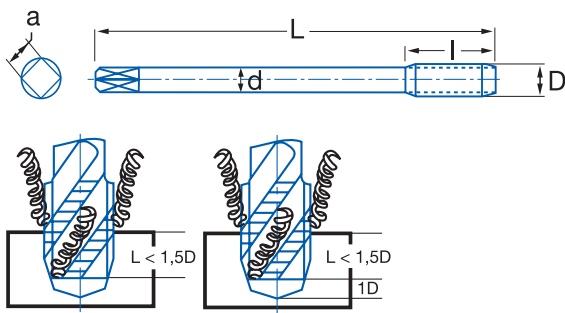

Material		Vc
Grupo	Sub.	TIALN
1	1.3	4-8
1	1.4	3-5
4		10-15
7	7.2	20-30

Vc= m/min.

M	P	L mm	l mm	d mm	a mm	Z	Nº Art. TIALN	€
M12	1,75	110	18	9,00	7,00	3	16399	54,96
M14	2,00	110	20	11,00	9,00	3	16400	72,11
M16	2,00	110	20	12,00	9,00	4	16401	91,09
M18	2,50	125	25	14,00	11,00	4	13218	124,81
M20	2,50	140	25	16,00	12,00	4	13219	133,98