

Ref. **3174**

MACHO RECTO MÁQUINA MÉTRICA ALUMINIO M. REFORZADO DENTADO ALTERNO
 Interrupted Thread Reinforced Shank Aluminium Metric Machine Straight Tap
 Taraud Droit Machine Metrique Aluminium Queue Renforcée Denture Alternée

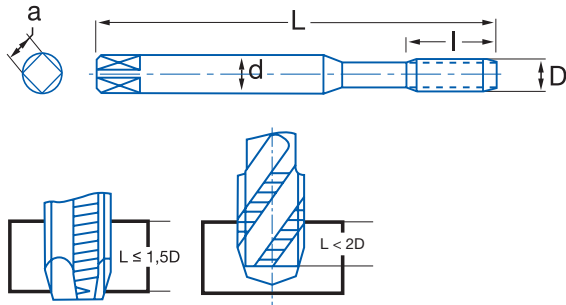

HSSE 5%Co	DIN 371	B 3,5-5h	GUN	Tol. 6H	α 17-20°	60°
--------------	------------	-------------	-----	------------	--------------------	-----



Material		Vc
Grupo	Sub.	5% Co
1	1.1	20-25
1	1.2	8-18
2	2.1	8-10
2	2.2	8-10
5	5.1	10-25
5	5.2	10-25
6	6.1	12-25
6	6.2	12-25
6	6.3	15-20
7	7.1	20-25

Vc= m/min.

M	P	L mm	l mm	d mm	a mm	Z	N° Art. 5% Co	€
M3	0,50	56	11	3,50	2,70	3	69390	19,98
M4	0,70	63	13	4,50	3,40	3	69393	19,98
M5	0,80	70	16	6,00	4,90	3	69394	19,98
M6	1,00	80	19	6,00	4,90	3	69396	21,03
M8	1,25	90	22	8,00	6,20	3	69397	25,16
M10	1,50	100	24	10,00	8,00	3	69399	29,63

Ref. **3274**

MACHO RECTO MÁQUINA MÉTRICA ALUMINIO DENTADO ALTERNO
 Interrupted Thread Aluminium Metric Machine Straight Tap
 Taraud Droit Machine Metrique Aluminium Denture Alternée



HSSE 5%Co	DIN 376	B 3,5-5h	GUN	Tol. 6H	α 17-20°	60°
--------------	------------	-------------	-----	------------	--------------------	-----

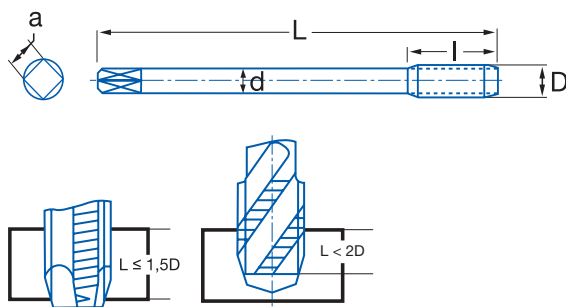

Material		Vc
Grupo	Sub.	5% Co
1	1.1	20-25
1	1.2	8-18
2	2.1	8-10
2	2.2	8-10
5	5.1	10-25
5	5.2	10-25
6	6.1	12-25
6	6.2	12-25
6	6.3	15-20
7	7.1	20-25

Vc= m/min.

M	P	L mm	l mm	d mm	a mm	Z	N° Art. 5% Co	€
M5	0,80	70	16	3,50	2,70	3	69853	19,98
New! M6	1,00	80	19	4,50	3,40	3	69855	25,16
M8	1,25	90	22	6,00	4,90	3	69856	25,16
M10	1,50	100	24	7,00	5,50	3	69858	29,63
M12	1,75	110	29	9,00	7,00	3	69859	37,00
M14	2,00	110	30	11,00	9,00	3	69861	67,03
M16	2,00	110	32	12,00	9,00	3	69862	67,45